

Section 3

800 Line

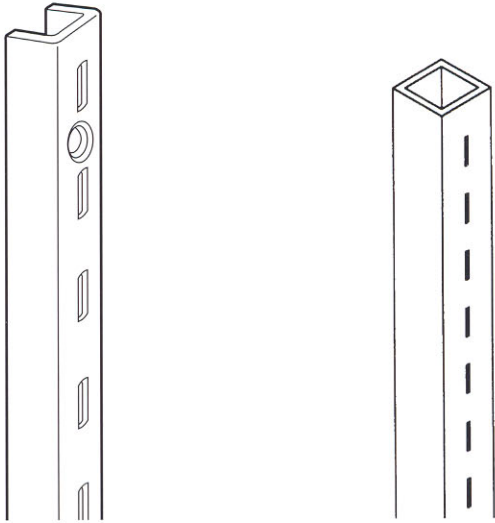

STANDARDS



BRACKETS

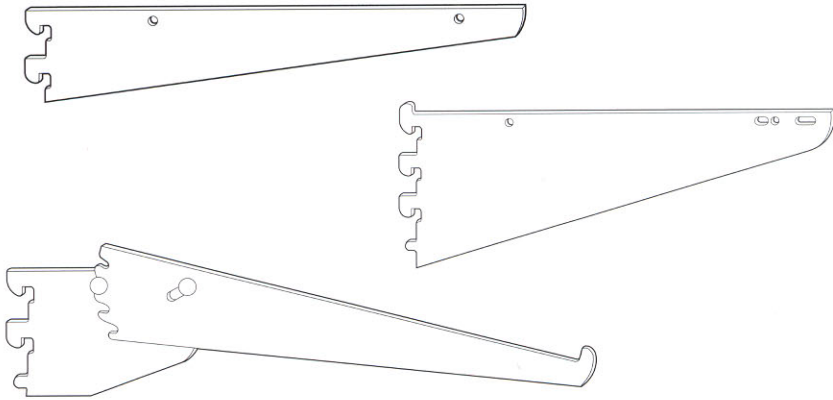

FACEOUTS

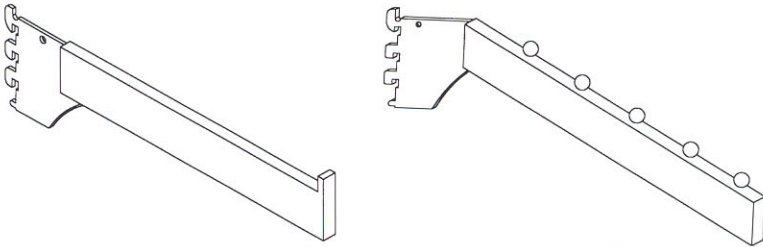

800 Standards are Slotted $\frac{1}{2}$ " at 1" On Center (Heavy Duty $\frac{1}{8}$ " thick material)

No. 800 Standard



Part Number	Length	Packed/Ctn	Wt./Ea.
800-4	4'	10	3 Lbs.
800-5	5'	10	3 $\frac{3}{4}$ Lbs.
800-6	6'	10	4 $\frac{1}{2}$ Lbs.
800-7	7'	10	5 $\frac{1}{4}$ Lbs.
800-8	8'	10	6 Lbs.

Use #8 Screw.

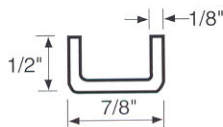

Application:
Heavy duty wall standards.

Features:
 $\frac{1}{8}$ " thick steel. On center dimension from counter-sunk screw hole to counter-sunk screw hole is 6".

Stock Finish:
Brillatone (Satin Zinc) and Polished Chrome.

No. 803/804/805 Standard

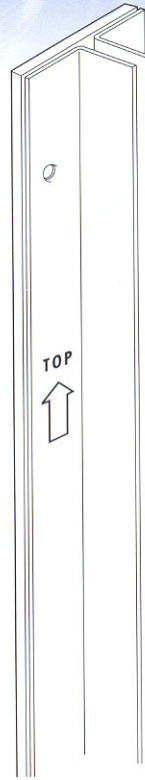

Part Number	Length	Packed/Ctn	Wt./Ea.
803-6	6'	14	6 Lbs.
803-8	8'	14	8 Lbs.
804-6	6'	10	7 Lbs.
804-8	8'	10	9 Lbs.
805-6	6'	8	7 Lbs.
805-8	8'	8	9 Lbs.

Use #10 Screw.

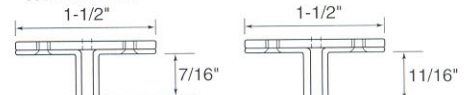

803

804

*Can be ordered to exact length required at no extra charge.

Application:
Loose fixtures and perimeters.

Refer to Section I for installation instructions.

Features:
 $\frac{1}{8}$ " thick steel. On center dimension from counter-sunk screw hole to counter-sunk screw hole is 6" staggered side to side.

Stock Finish:
Brillatone (Zinc) and P51 Black Powder Coat.

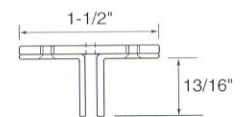

805

No. 885 1" Square Tube - Standard

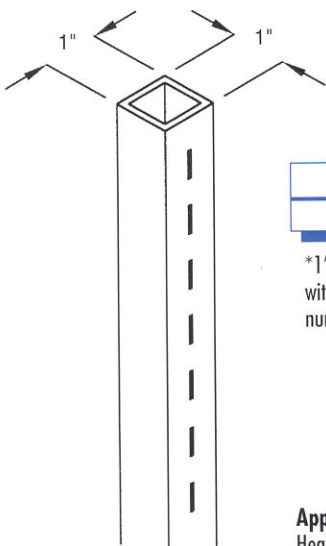

Part Number	Length
885-X	Made-to-order

*1"x 2" slotted tube standard also available with slotting on one or both 1" sides. Part number 880.

Application:
Heavy Duty welded frames, wall cases, and outriggers.

Features:
 $\frac{1}{8}$ " thick steel, single slotted. Available slotted on 1, 2, or 3 sides.

Stock Finish:
Made-to-Order.

No. 801 Slotted Strip

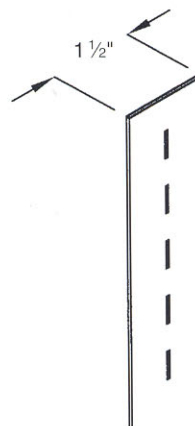

Part Number	Length
801-X	Made-to-order

Application:
Loose fixtures and back islands.

Features:
Single slotted strip with or without screw holes. Made-to-order at any length up to 10'. $\frac{1}{8}$ " thick steel.

Stock Finish:
Made-to-Order.

All items can be made-to-order in a wide variety of plated or powder coated finishes and/or custom lengths.

No. 500 Concealed Standard/Stud

Part Number	Length	Approx. Wt./Ea.
500-SX6 (1/2")	6'	1.27 Lbs./Lin. Ft.
500-SX8 (1/2")	8'	1.27 Lbs./Lin. Ft.
500-LX6 (5/8")	6'	1.27 Lbs./Lin. Ft.
500-LX8 (5/8")	8'	1.27 Lbs./Lin. Ft.
500-DX6 (1")	6'	1.27 Lbs./Lin. Ft.
500-DX8 (1")	8'	1.27 Lbs./Lin. Ft.

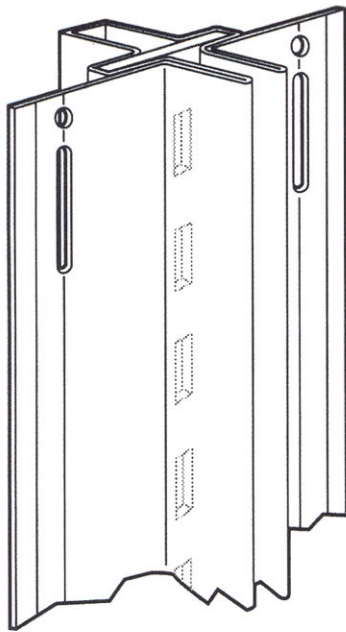

Application:

For moderate loads. Designed for use between your studs or with #510 stud.

Features:

Available for 1/2", 5/8" or 1" Wallboard.
1/8" thick slotted steel plate enclosed within roll formed 22-gauge galvanized steel.

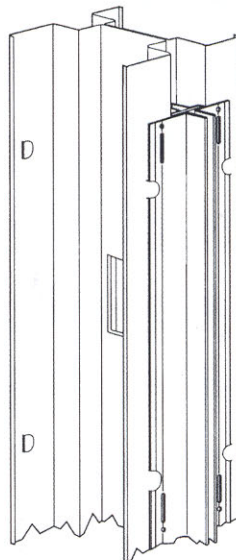

Part Number	Length	Approx. Wt./Ea.
510	Specify"	1.02 Lbs./Lin. Ft.

* Order to required length.

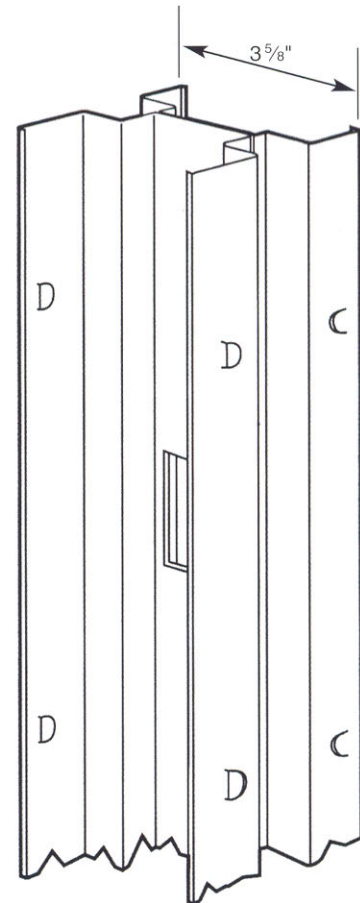

Application:

Designed to be use with #500 Standard.

Features:

Comes assembled with # 1000 25-gauge galvanized steel.

All items can be made-to-order in a wide variety of plated or powder coated finishes and/or custom lengths.

No. 841 Shelf Bracket

Application:
Perimeter and loose fixtures with glass or wood shelving.
See page 3.5 for shelf rest clips.

Features:
1/8" thick tempered steel. Slim profile.

Stock Finish:
Brillatone (Satin Zinc).

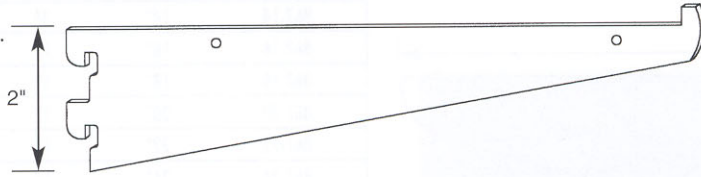

Part Number	Length	Packed/Ctn.	Wt./Ctn.
841-10	10"	24	8 Lbs.
841-12	12"	24	10 Lbs.
841-14	14"	24	14 Lbs.
841-16	16"	24	16 Lbs.
841-18	18"	24	20 Lbs.

No. 842 Shelf Bracket

Application:
Perimeter and loose fixtures with glass or wood shelving.
See page 3.5 for shelf rest clips.

Features:
1/8" thick tempered steel. Slim profile.

Stock Finish:
Brillatone (Satin Zinc) and Polished Chrome.

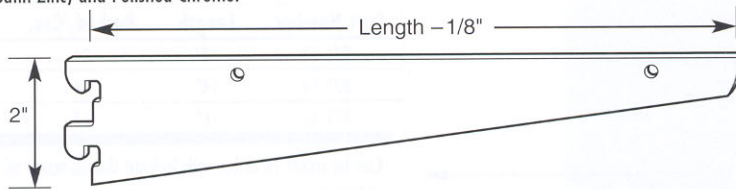

Part Number	Length	Packed/Ctn.	Wt./Ctn.
842-6	6"	24	4 Lbs.
842-8	8"	24	6 Lbs.
842-10	10"	24	8 Lbs.
842-12	12"	24	10 Lbs.
842-14	14"	24	14 Lbs.
842-16	16"	24	16 Lbs.
842-18	18"	12	20 Lbs.

No. 844 Shelf Bracket

Application:
Perimeter and loose fixtures with glass or wood shelving.
See page 3.5 for shelf rest clips.

Features:
1/8" thick tempered steel. Slim profile.
Uphook at standard for added stability and safety.

Stock Finish:
Brillatone (Satin Zinc).

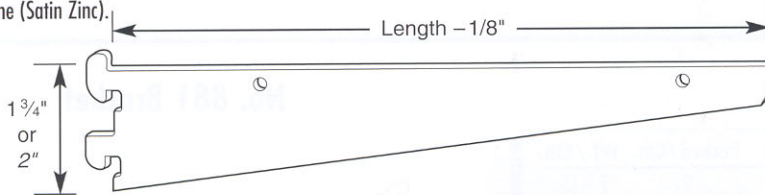

Part Number	Length	Packed/Ctn.	Wt./Ctn.
844-6	6"	12	4 Lbs.
844-8	8"	24	6 Lbs.
844-10	10"	24	8 Lbs.
844-12	12"	24	10 1/2 Lbs.
844-14	14"	24	15 Lbs.
844-16	16"] 2"	24	16 Lbs.

No. 843 Shelf Bracket (Adjustable Downslant)

Application:
Perimeter and loose fixtures with glass or wood shelving.

Features:
Tempered steel. Bracket is made of .080" thick medium duty material. Straight, 7°, 15°, 30°, and 45° downslant on 8", 10" and 12".
Straight, 7°, 15°, 30°, 45°, and 60° downslant on 14" and 16".

Stock Finish:
Brillatone (Satin Zinc).

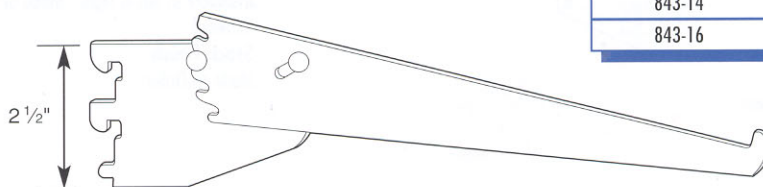

Part Number	Length	Packed/Ctn.	Wt./Ctn.
843-8	8"	12	3 1/2 Lbs.
843-10	10"	12	4 1/2 Lbs.
843-12	12"	12	5 Lbs.
843-14	14"	12	7 Lbs.
843-16	16"	12	7 3/4 Lbs.

All items can be made-to-order in a wide variety of plated or powder coated finishes and/or custom lengths.

No. 867 Shelf Bracket

Application:

Perimeter and loose fixtures with glass or wood shelving.
See page 3.5 for shelf rest clips.

Features:

Wider gusset for stronger weight capacity. 1/8" thick tempered steel.

Stock Finish: Brillatone (Satin Zinc) and Polished Chrome.

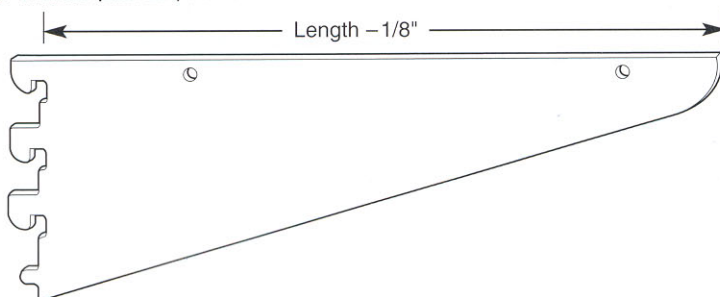

Part Number	Length	Packed/Ctn.	Wt./Ctn.
867-8	8"	24	8 Lbs.
867-10	10"	24	10 Lbs.
867-12	12"	24	12 Lbs.
867-14	14"	24	14 1/2 Lbs.
867-16	16"	12	17 1/4 Lbs.
867-18	18"	12	20 Lbs.
867-20	20"	12	22 Lbs.
867-22	22"	12	24 1/4 Lbs.
867-24	24"	12	27 Lbs.

*Can be made to order with locknut thumb screw to reduce sway.

No. 871 Shelf Bracket

Application:

Perimeters, loose fixtures, and hangrod.
See page 3.5 for shelf rest clips.

Features:

1/8" thick tempered steel. Uphook for added stability and safety.

Stock Finish: Brillatone (Satin Zinc) and Polished Chrome.

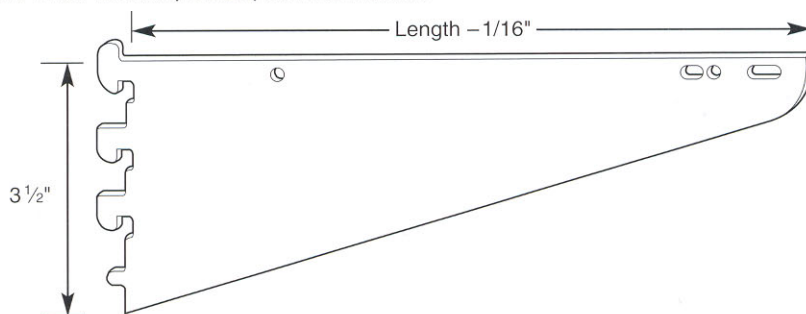

Part Number	Length	Packed/Ctn.	Wt.
871-12	12"	24	14 1/2 Lbs.
871-14	14"	24	14 1/2 Lbs.
871-16	16"	12	17 1/4 Lbs.

*Can be made to order with locknut thumb screw to reduce sway.

No. 824 Cornice Bracket

Part Number	Adj. Length	Packed/Ctn.	Wt./Ctn.
824	24"-36"	2	7 1/2 Lbs.

* Can be made to exact length required. Can be made to order with locknut thumb screw to reduce sway.

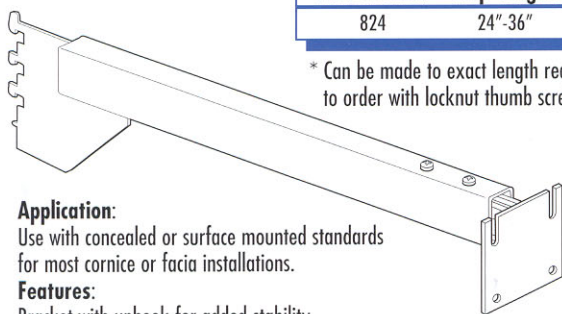

Application:

Use with concealed or surface mounted standards for most cornice or fascia installations.

Features:

Bracket with uphook for added stability and safety. 1" x 1 1/2" x 24" long tube.

Adjustable insert allows additional 12" extension.

1/8" thick tempered steel stub bracket.

Stock Finish:

Brillatone (Satin Zinc).

No. 881 Bracket

Application:

Wood shelf bracket fits 800 line standards. Available in left & right. Made of medium duty material.

Stock Finish:

Made-to-Order.

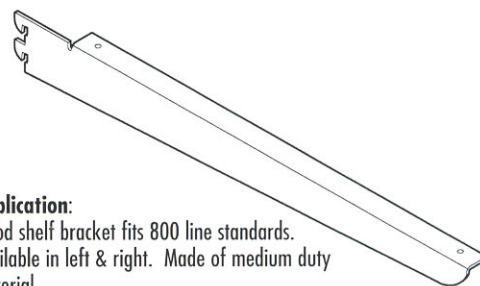

All items can be made-to-order in a wide variety of plated or powder coated finishes and/or custom lengths.

No. V848 Faceout

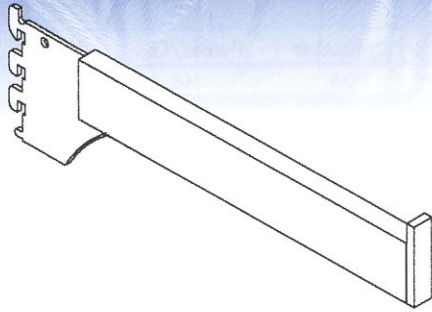

Application:
For merchandising on perimeters and loose fixtures.

Features:
Plastic end stop. $\frac{1}{2}$ " x $1\frac{1}{2}$ " tube.
 $\frac{1}{8}$ " thick tempered steel stub bracket.

Stock Finish:
Value Line Chrome.

Part Number	Length	Packed/Ctn.	Wt./Ctn.
V848-12	12"	12	15 Lbs.

*Can be made to exact length required.

No. A848 Adjustable Gusset Faceout

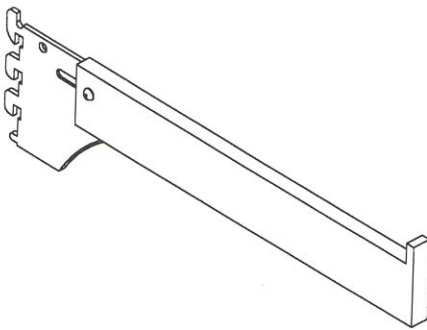

Application:
For merchandising on perimeters, loose fixtures, and back islands.

Features:
Welded, ground, and polished end cap.
Tab or flush end cap available.
Adjustable $\frac{1}{8}$ " thick stub bracket allows for flush installation.

Stock Finish:
Made-to-order.

Part Number	Length
A848-X	Made-to-order

*Can be made to exact length required.

No. 848 Faceout

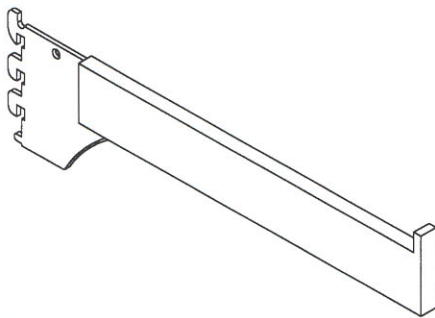

Application:
For faceout merchandising on perimeters and loose fixtures.

Features:
Welded, ground, and polished end stop.
 $\frac{1}{2}$ " x $1\frac{1}{4}$ " tube. $\frac{1}{8}$ " thick tempered steel stub bracket.

Stock Finish:
Polished Chrome.

Part Number	Length	Packed/Ctn.	Wt./Ctn.
848-6	6"	12	9 Lbs.
848-12	12"	12	13 Lbs.

*Can be made to exact length required. Can be made to order with locknut thumb screw to reduce sway.

No. 847 Waterfall Faceout

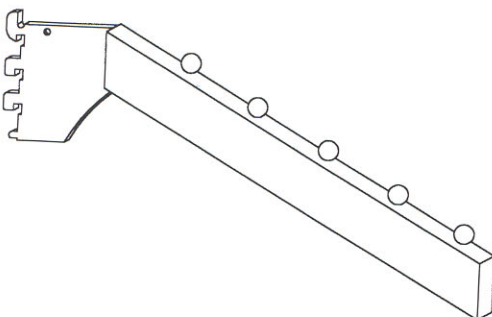

Application:
For merchandising on perimeters and loose fixtures.

Features:
30° downslant. Welded, ground, and polished end cap. $\frac{1}{2}$ " x $1\frac{1}{4}$ " tube.
 $\frac{1}{8}$ " thick tempered steel stub bracket.

Stock Finish:
Polished Chrome.

Part Number	Length	Packed/Ctn.	Wt./Ctn.
847-12-B	12" (5 Balls)	12	15 Lbs.
847-16-B	16" (6 Balls)	12	17 Lbs.

*Can be made to order with locknut thumb screw to reduce sway. Can be made with cube stops also.

All items can be made-to-order in a wide variety of plated or powder coated finishes and/or custom lengths.

Shelf Rest Clips

No. 743-L Shelf Rest (Left)

Part Number	Packed/Ctn.	Wt./Ctn.
743-L	144	4 Lbs.

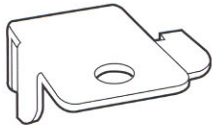

Application:
Use with shelf brackets with mounting holes. Designed for flush fit with bracket and shelf.

Features:
Swivel-lock. Gray rubber suction cushions are included to secure glass shelves.

Stock Finish:
Brillatone (Zinc).

No. 743-C Shelf Rest (Center)

Part Number	Packed/Ctn.	Wt./Ctn.
743-C	144	6 Lbs.

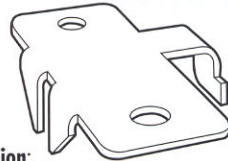

Application:
Use with shelf brackets with mounting holes. Designed for center brackets and at ends with shelf overhang.

Features:
Swivel-lock. Gray rubber suction cushions are included to secure glass shelves.

Stock Finish:
Brillatone (Zinc).

No. 743-R Shelf Rest (Right)

Part Number	Packed/Ctn.	Wt./Ctn.
743-R	144	4 Lbs.

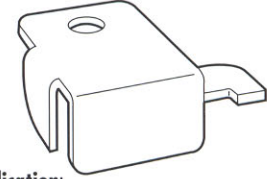

Application:
Use with shelf brackets with mounting holes. Designed for flush fit with bracket and shelf.

Features:
Swivel-lock. Gray rubber suction cushions are included to secure glass shelves.

Stock Finish:
Brillatone (Zinc).

No. 743-P-L Shelf Rest (Left)

Part Number	Packed/Ctn.	Wt./Ctn.
743-P-L	144	2 Lbs.

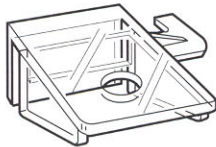

Application:
Made of clear lexan plastic for use with special finish brackets to maintain a clean profile.

Features:
Swivel-lock. Clear suction cushions are included to secure glass shelves.

No. 743-P-C Shelf Rest (Center)

Part Number	Packed/Ctn.	Wt./Ctn.
743-P-C	144	3 Lbs.

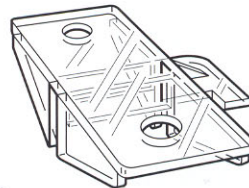

Application:
Made of clear lexan plastic for use with special finish brackets to maintain a clean profile. Designed for center brackets and at ends with shelf overhang.

Features:
Swivel lock. Clear suction cushions are included to secure glass shelves.

No. 743-P-R Shelf Rest (Right)

Part Number	Packed/Ctn.	Wt./Ctn.
743-P-R	144	2 Lbs.

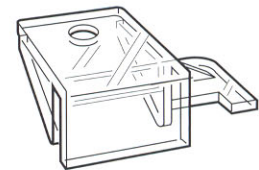

Application:
Made of clear lexan plastic for use with special finish brackets to maintain a clean profile.

Features:
Swivel lock. Clear suction cushions are included to secure glass shelves.

No. W-743-L Shelf Rest (Left)

Part Number	Packed/Ctn.	Wt./Ctn.
W-743-L	144	5 Lbs.

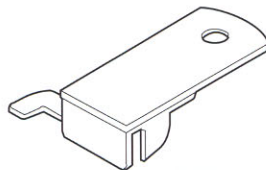

Application:
Double width for added safety. Designed for flush fit with bracket and shelf.

Features:
Swivel-lock. Gray rubber suction cushions are included to secure glass shelves.

Stock Finish:
Brillatone (Zinc).

No. W-743-C Shelf Rest (Center)

Part Number	Packed/Ctn.	Wt./Ctn.
W-743-C	144	6 Lbs.

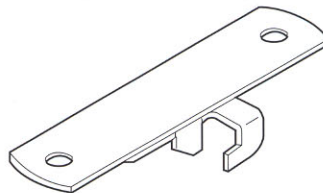

Application:
Double width for added safety. Designed for center brackets and at ends with shelf overhang.

Features:
Swivel-lock. Gray rubber suction cushions are included to secure glass shelves.

Stock Finish:
Brillatone (Zinc).

No. W-743-R Shelf Rest (Right)

Part Number	Packed/Ctn.	Wt./Ctn.
W-743-R	144	5 Lbs.

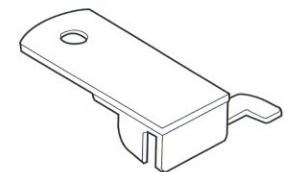

Application:
Double width for added safety. Designed for flush fit with bracket and shelf.

Features:
Swivel-lock. Gray rubber suction cushions are included to secure glass shelves.

Stock Finish:
Brillatone (Zinc).

Some items can be made-to-order in a wide variety of plated or powder coated finishes.

Hangrod Brackets

No. V825-2 Hangrod Bracket

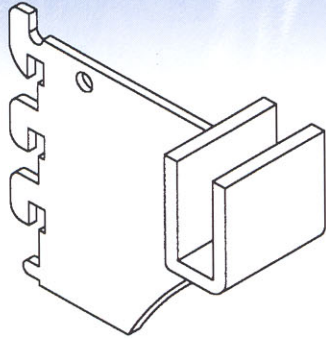

Application:
Fits 800 Line. Designed for use with No. 225 hangrod and faceouts.

Features:
 $\frac{3}{16}$ " thick saddle. Uphook for added strength and stability.

Stock Finish:
Value Line Chrome.

Part Number	Length	Packed/Ctn.	Wt./Ctn.
V825-2	2"	12	7 Lbs.

*Can be made with locknut thumb screw to reduce sway.

No. 825-4 Hangrod Bracket

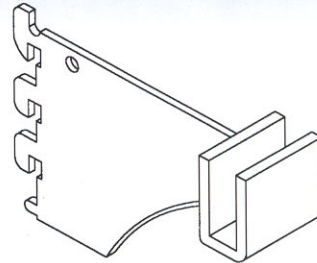

Application:
For use with No. 225 Hangrod. Fits 800 Series standards.

Features:
Uphook for added stability and safety.
 $\frac{3}{16}$ " thick saddle. Left hand and right hand available.

Stock Finish:
Polished Chrome.

Part Number	Length	Packed/Ctn.	Wt./Ctn.
825-L/C/R-4	4"	12	7 ¼ Lbs.

*Can be made with locknut thumb screw to reduce sway.
Can be made to exact length required.

No. V865-12 Hangrod Bracket

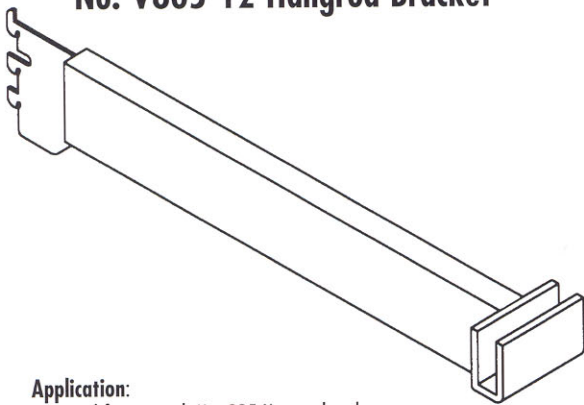

Application:
Designed for use with No. 225 Hangrod and 800 Series Standards.

Features:
 $\frac{3}{16}$ " thick saddle. $\frac{1}{2}$ " x $1\frac{1}{2}$ " tube.

Stock Finish:
Value Line Chrome.

Part Number	Length	Packed/Ctn.	Wt./Ctn.
V865-12	12"	12	13 Lbs.

*Can be made with locknut thumb screw to reduce sway.
Can be made to exact length required.

No. 825 Hangrod Bracket

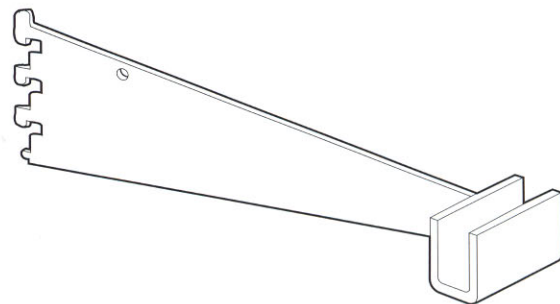

Application:
For use with No. 225 Hangrod and 800 Series Standards.

Features:
Uphook for added strength and stability. $\frac{3}{16}$ " thick saddle.
Left hand and right hand available.

Stock Finish:
Polished Chrome.

Part Number	Length	Packed/Ctn.	Wt./Ctn.
825-L/C/R-12	12"	12	13 Lbs.

*Can be made with locknut thumb screw to reduce sway.
Can be made to exact length required.

All items can be made-to-order in a wide variety of plated or powder coated finishes and/or custom lengths.